

Modular Fenders

MV Elements
V Fenders
MI Elements

Section 2



Trelleborg Marine Systems

www.trelleborg.com/marine

Ref. M1100-S02-V1.1-EN

TRELLEBORG

MV ELEMENTS

MV-elements are the foundation of many fender systems. These modular units are compression moulded from a high performance polymer which resists attack from ultraviolet light, ozone and immersion in seawater for long service life and low maintenance.

Available in a full range of sizes, the geometry of the MV-element has been optimised for maximum energy absorption per unit volume of rubber combined with a low reaction force. Fully encapsulated steel mounting plates are vulcanised inside the MV-element to allow easy fixing. Bolts are located centrally on the base flanges to reduce stresses, but being recessed into pockets the fixings are well protected from damage.

Features

- ▮ Modular design system
- ▮ Many standard sizes
- ▮ High performance geometry
- ▮ Recessed fixings
- ▮ Long life, low maintenance

Applications

All vessel types which use the following systems:

- ▮ Fender piles
- ▮ V-fenders
- ▮ Multiple fenders
- ▮ Pivot pillars
- ▮ Parallel Motion (Torsion Arm)



MV ELEMENT

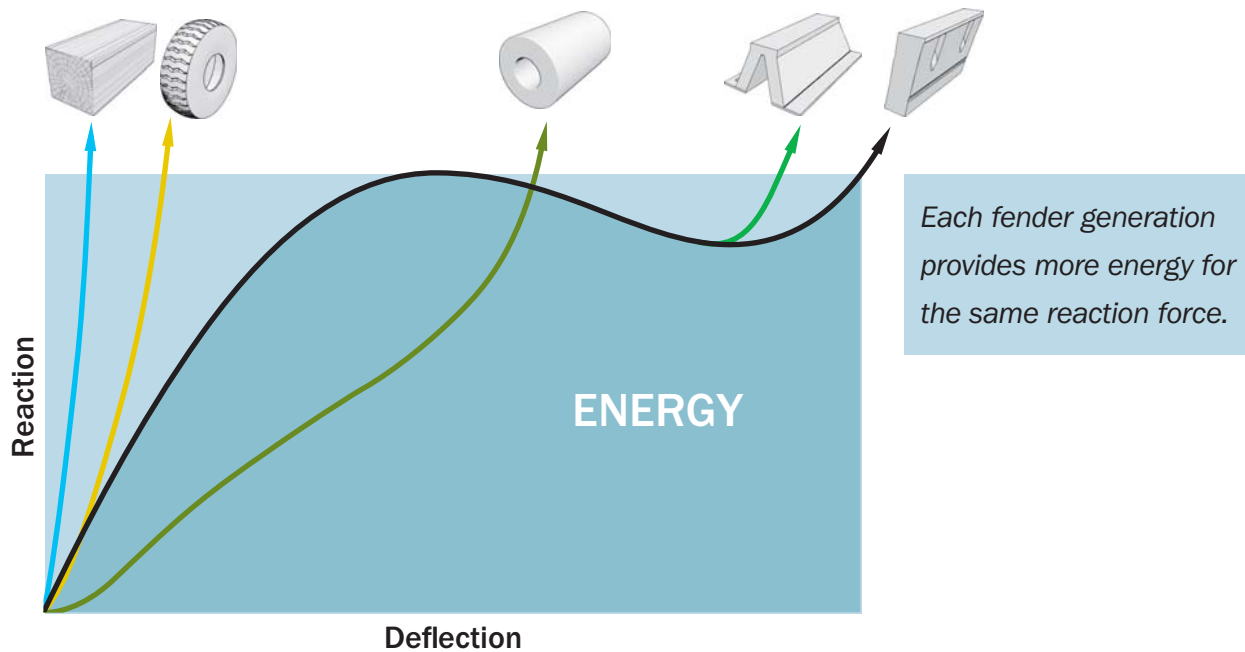

Fender Evolution

Ships have grown larger – so have the demands on fenders. A century ago timber (1st Generation) was cheap and worked adequately for the small vessels of the day. Old tyres (2nd Generation) were abundant and softer but required expensive maintenance and absorbed little energy.

Cylindricals (3rd Generation) were the first purpose designed fenders, gaining popularity some 50 years ago, but inefficient use of rubber and low performance by today's standards makes them costly. Arch and simple buckling fenders (4th Generation) had better performance and integrated the rubber with steel fixing plates.

5th Generation Fenders

MV-elements are 5th Generation fenders. With refined geometry the rubber has a characteristic double-buckle 'S' shape. This gives the MV-element a greater deflection for the same reaction so it absorbs more energy than all previous generations with less material.

Modular Design

MV-elements are modular so can be installed horizontally or vertically, close together or further apart, with the 'V' facing towards or away from the panel.

'A' and 'B' compounds can be mixed or different lengths used – allowing almost limitless permutations and giving the designer greater control on how an MV-system behaves when impacted.

MV-element

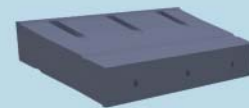

V-fender



System fender

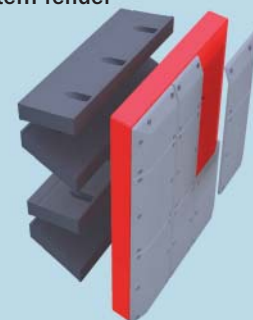

MV300 elements up to 3000mm available on request.

MV ELEMENT

Dimensions

	L	B	C	D	E	F	G	J	T	Anchor	Holes	Weight
MV300	600	150	300	150	300	94	93	47	17	M20	2 + 2	27
	900										3 + 3	41
	1200										4 + 4	54
	1500										5 + 5	68
MV400	750	125	500	125	500	125	124	63	17	M24	2 + 2	50
	1000	250		250							2 + 2	66
	1500	250		250							3 + 3	99
	2000	250		250							4 + 4	132
	2500	250		250							5 + 5	165
	3000	250		250							6 + 6	198
MV500	750	125	500	125	500	158	142	87	20	M30	2 + 2	84
	1000	250		250							2 + 2	111
	1500										3 + 3	167
	2000										4 + 4	222
	2500										5 + 5	278
	3000										6 + 6	334
MV550	750		125		500	125	500	172	170	87	20	M30
	1000	250	250	2 + 2		132						
	1500	3 + 3	200									
MV600	750	125	500	125	500	188	199	87	20	M30	2 + 2	115
	1000	250		250							2 + 2	153
	1500										3 + 3	230
MV750	750		125		500	125	500	235	230	118	26	M36
	1000	250	250	2 + 2		239						
	1500	3 + 3	359									
MV800	800	150	500	150	500	250	240	129	26	M36	2 + 2	214
	1000	250		250							2 + 2	268
	1500										3 + 3	402
	2000										4 + 4	536
MV1000	800		150		500	150	500	322	310	162	31	M42
	850	175	175	2 + 2		368						
	900	200	200	2 + 2		389						
	950	225	225	2 + 2		411						
	1000	250	250	2 + 2		432						
	1050	275	275	2 + 2		454						
	1100	300	300	2 + 2		476						
	1150	325	325	2 + 2		497						
	1200	350	350	2 + 2		519						
	1500	250	250	3 + 3		648						
	2000			4 + 4		864						

MV ELEMENT

Dimensions

	L	B	C	D	E	F	G	J	T	Anchor	Holes	Weight
MV1250	800	150	500	150	500	401	388	202	36	M48	2 + 2	511
	850	175		175							2 + 2	543
	900	200		200							2 + 2	575
	950	225		225							2 + 2	607
	1000	250		250							2 + 2	639
	1050	275		275							2 + 2	671
	1100	300		300							2 + 2	703
	1150	325		325							2 + 2	735
	1200	350		350							2 + 2	767
	1250	375		375							2 + 2	799
	1500	250		250							3 + 3	959
	2000										4 + 4	1278
MV1450	900	200	500	200	500	454	445	228	41	M48	2 + 2	786
	1000	250		250							2 + 2	873
	1100	300		300							2 + 2	960
	1200	350		350							2 + 2	1048
	1500	250		250							3 + 3	1310
	2000										4 + 4	1746
MV1600	1000	250	500	250	500	507	480	261	50	M56	2 + 2	1114
	1100	300		300							2 + 2	1226
	1200	350		350							2 + 2	1337
	1500	250		250							3 + 3	1671
	2000										4 + 4	2228

[Units: mm, kg]

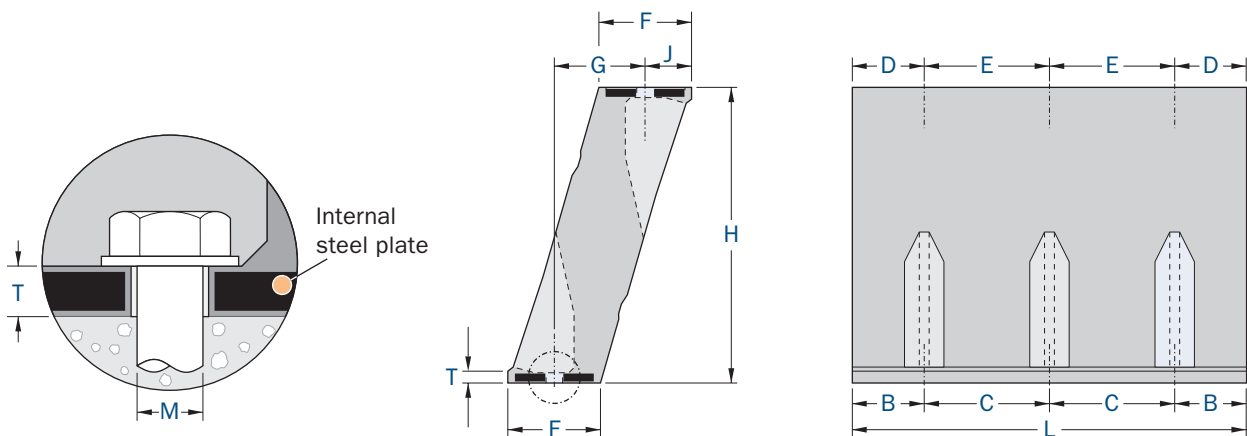

MV ELEMENT

Rated Performance Data (RPD)*

	L	Compound A		Compound B	
		E	R	E	R
MV300	600	12.6	91.4	8.8	64
	900	18.9	137	13.2	96
	1200	25.2	183	17.7	128
	1500	31.5	229	22.1	160
MV400	750	26.9	146	18.8	102
	1000	37.4	203	26.2	142
	1500	56.1	305	39.3	213
	2000	74.8	406	52.3	284
	2500	93.5	508	65.4	356
MV500	3000	112	609	78.5	427
	750	41.2	179	28.9	125
	1000	58.4	254	40.9	178
	1500	87.6	381	61.3	267
MV550	2000	117	508	81.8	356
	750	49.9	197	34.9	138
	1000	70.7	279	49.5	196
MV600	1500	106	419	74.2	293
	750	59.4	215	41.6	151
	1000	84.1	305	58.9	213
MV750	1500	126	457	88.3	320
	750	90.4	262	63.2	183
	1000	131	381	92	267
MV800	1500	197	571	138	400
	800	111	302	77.8	212
	1000	150	406	105	284
	1500	224	609	157	427
MV1000	2000	299	813	209	569
	800	175	380	122	266
	850	189	412	133	288
	900	204	444	143	311
	950	219	476	153	333
	1000	234	508	164	356
	1050	248	540	174	378
	1100	263	572	184	400
	1150	278	604	195	423
MV1250	1200	293	636	205	445
	1500	350	762	245	533
	2000	467	1016	327	711
	800	269	468	188	327
	850	293	510	205	357
	900	317	551	222	386
	950	341	593	239	415
	1000	365	635	256	444
	1050	389	677	272	474
	1100	413	718	289	503
MV1450	1150	437	760	306	532
	1200	461	802	323	561
	1250	485	844	340	591
	1500	548	952	383	667
	2000	730	1270	511	889
	900	426	638	298	447
	1000	491	736	344	516
	1100	557	835	390	584
MV1600	1200	622	933	436	653
	1500	737	1105	516	773
	2000	982	1473	688	1031
	1000	598	813	419	569
	1100	690	937	483	656
MV1600	1200	781	1061	547	743
	1500	897	1219	628	853
	2000	1196	1625	837	1138

All performance values are for a single element.

[Units: kNm, kN]

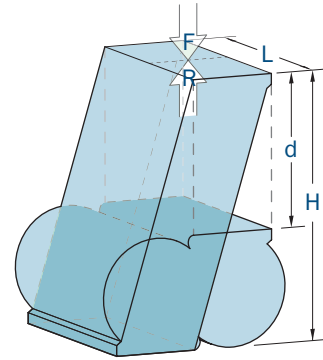

*Rated Performance Data (RPD)

Method: Decreasing Velocity (DV)

Temperature: 23°C

Initial speed: 150mm/s

Compression angle: 0°

Refer to p2-7.



MV ELEMENT

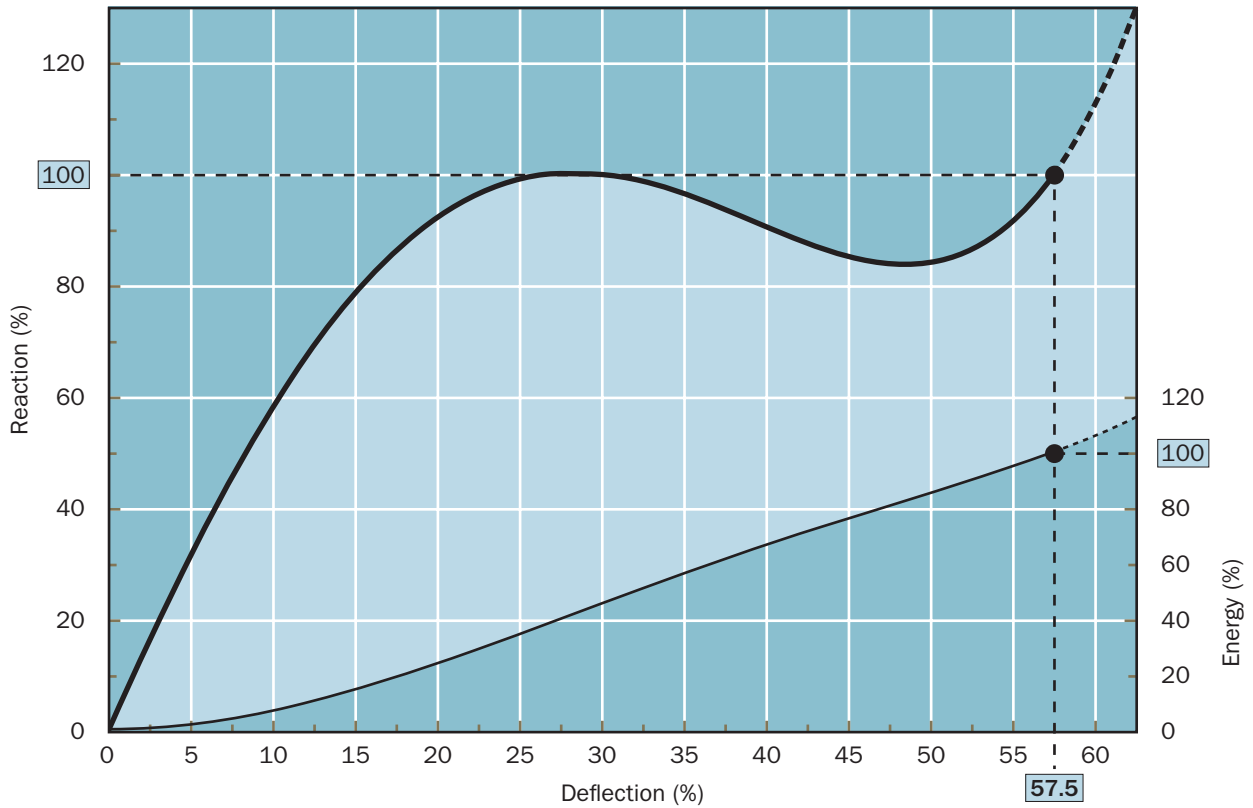

Intermediate deflections

example

D_i (%)	0	5	10	15	20	28	35	40	45	50	57.5	62.5
E_i (%)	0	2	7	14	24	41	56	66	76	85	100	113
R_i (%)	0	31	58	78	92	100	96	90	85	84	100	130

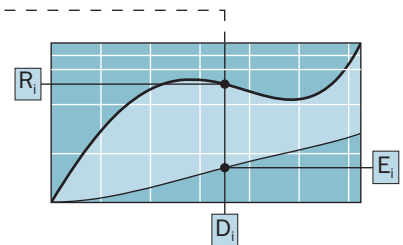

Nominal rated deflection may vary at RPD. Refer to p12-35.

Decreasing Velocity (DV) test method

The Trelleborg high-speed test press was developed to simulate real berthing conditions for MV and MI elements. Depending on element size, initial speeds exceeding 300mm/s are achievable.

The test press can accommodate single elements from MV500 to MV1600 as well as the MI2000 in lengths up to 1500mm.

Please refer to Trelleborg Marine Systems for all special test requirements.



MV SYSTEMS

Element spacing

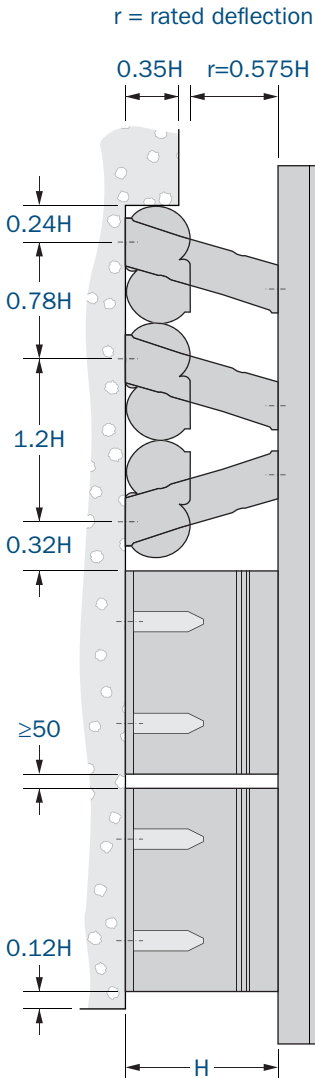

MV-elements can be mounted horizontally or vertically. There must be enough space around and between MV-element fenders and the steel panel to allow them to deflect without interference.

Distances given in the diagram are for guidance. If in doubt, contact your local office.

Weight support

MV-elements can support a lot of weight. The table is a guide to the permitted weight of the front panel in tonnes per metre of element pair before additional support chains may be required.

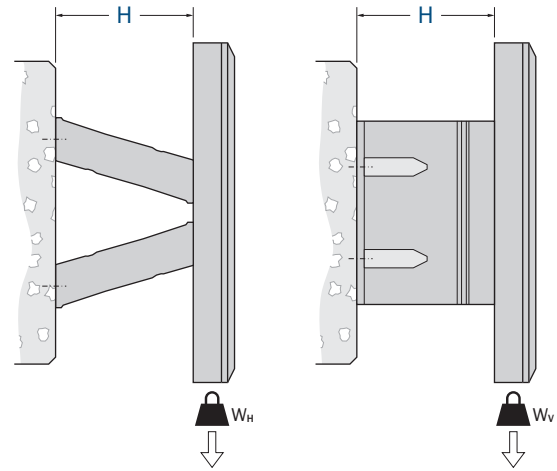

MV	Panel weight* (kg)	
	Single or multiple horizontal	Single or multiple vertical
Compound A	$W_H \leq 1.0 \times H \times L$	$W_V \leq 1.78 \times H \times L$
Compound B	$W_H \leq 0.7 \times H \times L$	$W_V \leq 1.25 \times H \times L$

* per pair of elements.

Shear stiffness

Some temporary shear may be caused by friction as the MV-elements are compressed. Maximum shear usually occurs at approximately 28% deflection.

$$D_L \approx 0.39 \times \mu \times H$$

$$D_T \approx 0.82 \times \mu \times H$$

Where,

H = fender height

μ = friction coefficient

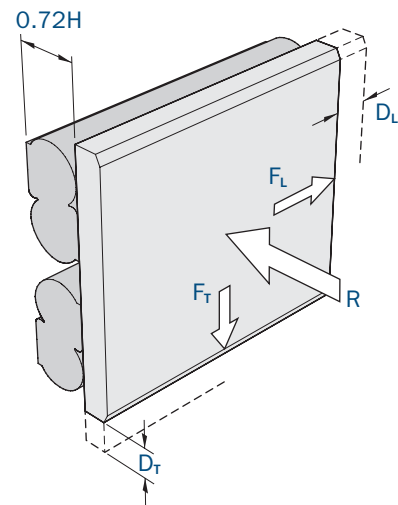

Tension

If the likely tensile load exceeds the rated reaction then tension chains may be required. Please refer to your local office.

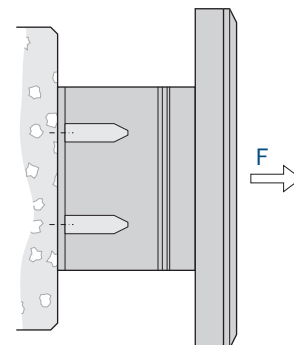

MV SYSTEMS

**Proven
in practice**

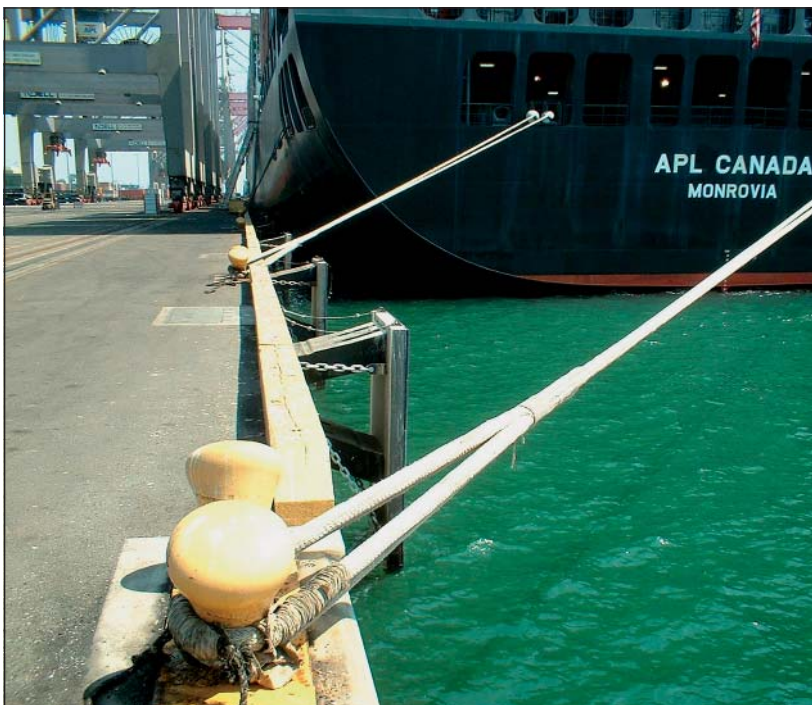
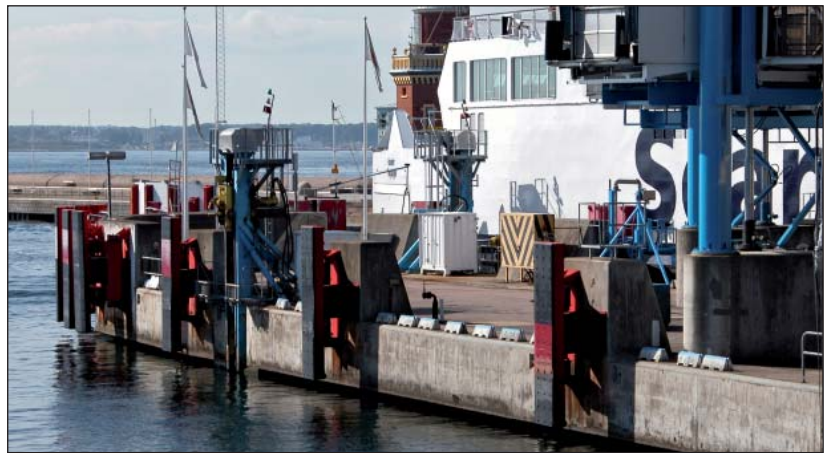

V-FENDERS

V-fenders fulfil the need for a simple, and maintenance-free fender system with high performance and a robust design at low costs. All V-fenders use one or several pairs of MV-elements and a front shield. The shield is a structural component of the fender, directly bolted to the MV-element and easily able to withstand constant use in busy harbours.

The UHMW-PE face is also very gentle on ships. It will conform to the contours of the hull, will not mark paint (unlike rubber) and does not spark. UHMW-PE has very low friction which reduces stresses in the V-fenders and fixings.

Applications

- | General cargo quays
- | Berthing dolphins
- | Pontoon fendering
- | Passenger ferry berths
- | Offshore platforms
- | Long fender walls

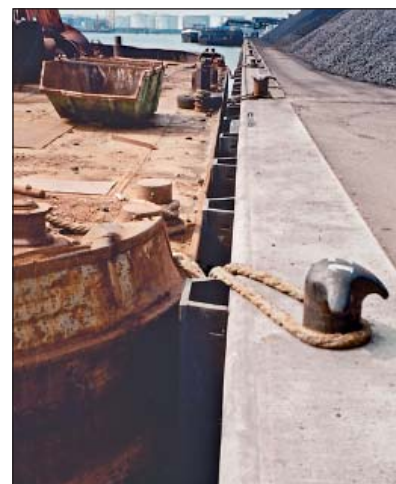

V-FENDERS

Dimensions

H	T(min)	So	M _w	S _w	A	B	C	Fixings
MV300P*	70	370	270	410	360	454	172	M20
MV400P	80	480	360	500	480	606	232	M24
MV500P	90	590	460	660	600	774	316	M30
MV550P	90	640	500	750	660	834	320	M30
MV600P	90	690	530	800	720	894	322	M30
MV750P	100	850	680	1010	900	1136	440	M36
MV800P	100	900	730	1170	960	1218	480	M36
MV1000P	120	1120	900	1330	1200	1524	580	M42
MV1250P	120	1370	1140	1660	1500	1904	724	M48

Please ask for other dimensions

[Units: mm]

* MV300 not available in 1000mm length (refer to p2-4).

Performance is for a pair of elements, 1000mm long.

Performance (per metre)

Compound A		Compound B	
E	R	E	R
42.0	305	29.5	213
74.8	406	52.4	284
117	508	81.8	356
141	558	99.0	392
168	610	118	426
262	762	184	534
300	812	210	568
468	1016	328	712
730	1270	512	888

[Units: kNm, kN]

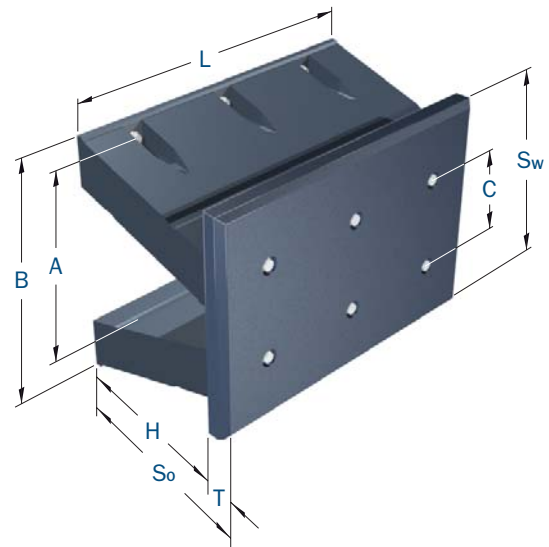
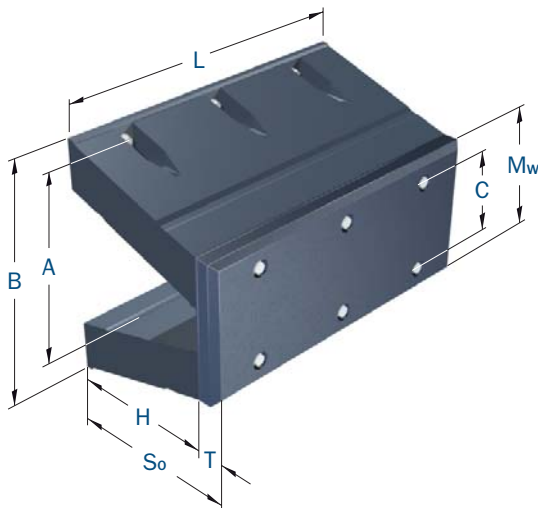

Always specify 'P' type elements for V-fenders (ie. MV500P). These have special internal plates designed to flex with the UHMW-PE shield. The flange marked 'Panel Side' should be connected to the shield.

All V-fender performances are based on decreasing velocity (DV) method compression testing of full size elements. Performances are valid for 150mm/s initial impact velocity, 23°C ambient temperature and 0° compression angle.

Site operating conditions or project specifications may differ from the above. Please ask your local Trelleborg Marine Systems office for further details, or visit our web site.



MI-2000 ELEMENTS

MI-2000 fender systems suit very large vessels and high energy applications. They share the modular design concept with MV elements but with a modified fixing arrangement to allow greater deflections and efficiency.

The rubber unit is available in several standard lengths and rubber grades which, combined with the modularity of the MI system, provides designers with greater choice and versatility.



Features

- | Modular design system
- | Choice of lengths and rubber grades
- | High performance and efficiency
- | Long, life, low maintenance

Applications

Ideal for larger vessels including:

- | Tankers and LNG ships
- | Bulk carriers
- | Post-Panamax containers
- | Mega cruise ships

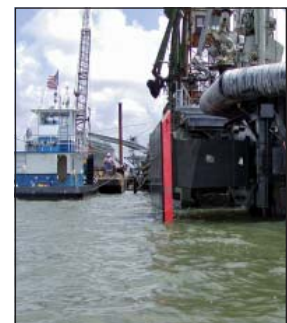
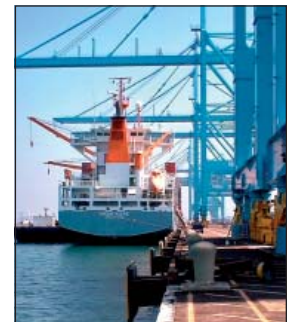

MI-2000 ELEMENTS

MI-2000 Dimensions

A	B	C	Anchor	Holes	Weight
1000	1270	1130	M42	6+6	1840
1050	1320	1180	M42	6+6	1941
1100	1370	1230	M42	6+6	2042
1150	1420	1280	M42	6+6	2144
1200	1470	1330	M42	6+6	2245
1250	1520	1380	M42	6+6	2346
1300	1570	1430	M42	6+6	2447
1350	1620	1480	M42	6+6	2549
1400	1670	1530	M42	6+6	2650

[Units: mm, kg]

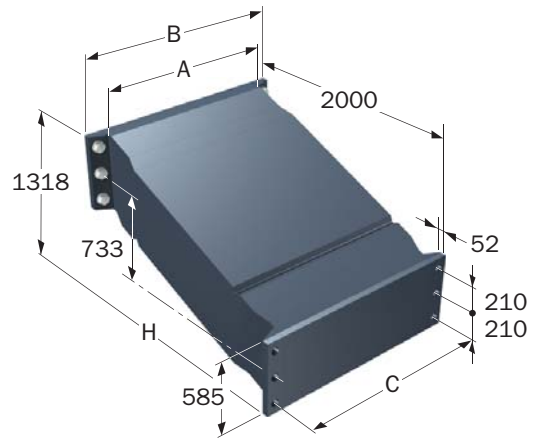

MI-2000S Dimensions

A	B	C	Anchor	Holes	Weight*
1000	1270	1130	M42	6+6	2191
1050	1320	1180	M42	6+6	2286
1100	1370	1230	M42	6+6	2383
1150	1420	1280	M42	6+6	2480
1200	1470	1330	M42	6+6	2573
1250	1520	1380	M42	6+6	2670
1300	1570	1430	M42	6+6	2765
1350	1620	1480	M42	6+6	2860
1400	1670	1530	M42	6+6	2957

[Units: mm, kg]

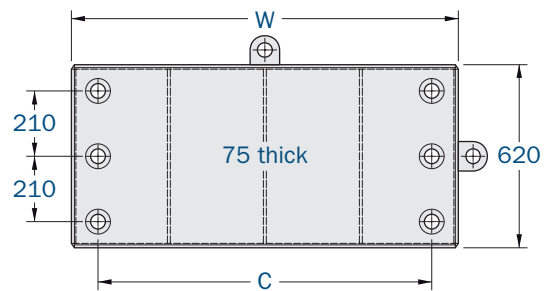
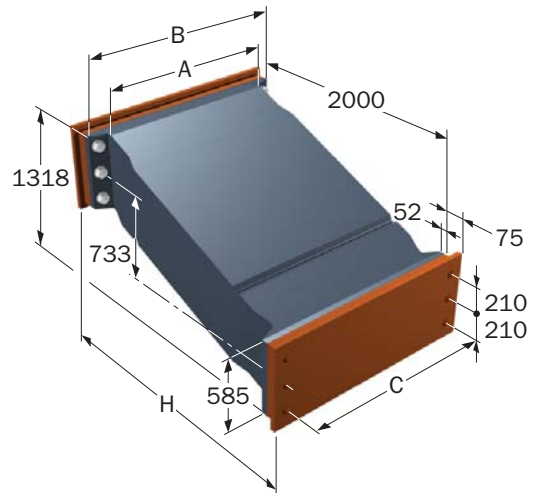

* MI-2000S weight includes fabricated spacers for both flanges (supplied with fender elements on request).

MI-2000

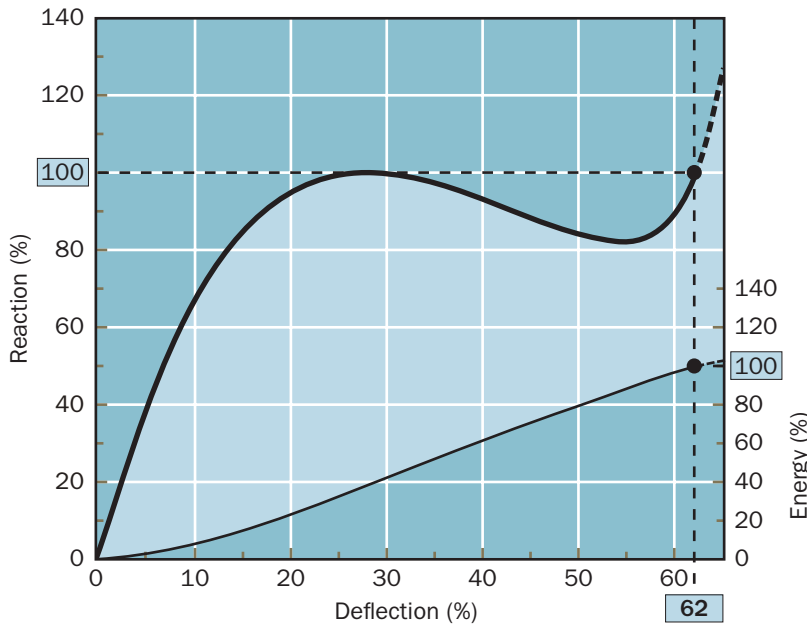

MI-2000 Performance

A		Compound A	Compound B
1000	E _R	925	565
	R _R	925	565
1050	E _R	971	593
	R _R	971	593
1100	E _R	1017	621
	R _R	1017	621
1150	E _R	1063	650
	R _R	1063	650
1200	E _R	1110	678
	R _R	1110	678
1250	E _R	1156	706
	R _R	1156	706
1300	E _R	1202	734
	R _R	1202	734
1350	E _R	1248	763
	R _R	1248	763
1400	E _R	1295	791
	R _R	1295	791

All values are for a single element. [Units: kN, kNm]

Intermediate deflections

D _i (%)	0	5	10	15	20	25	30	35	40	45	50	55	60	62	65
E _i (%)	0	2	6	14	23	32	42	52	61	71	79	88	96	100	103
R _i (%)	0	34	63	84	95	99	100	98	95	91	86	82	90	100	127

Nominal rated deflection may vary at RPD. Refer to p12-35.

example

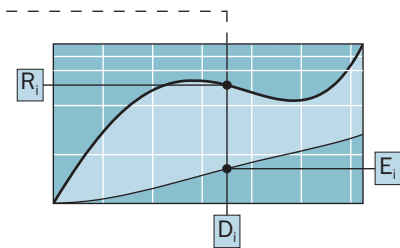

All MI-2000 performance values are based on decreasing velocity (DV) method compression testing of full size elements on a dedicated high speed test press. Performances are valid for 150mm/s initial impact velocity, 23°C ambient temperature and 0° compression angle.

Site operating conditions or project specifications may differ from the above. Please ask your local Trelleborg Marine Systems office for further details, or visit our web site.

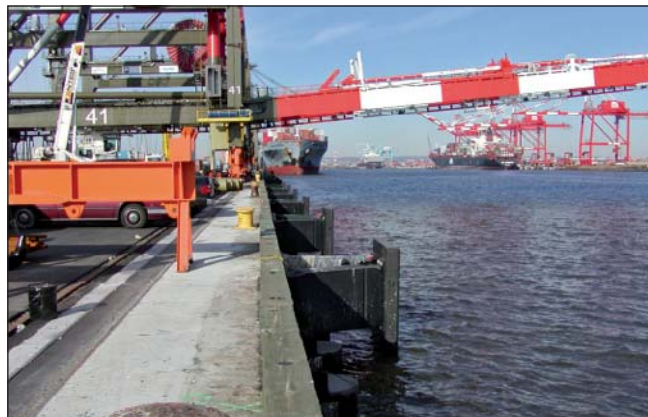

MI-2000S

MI-2000S Performance

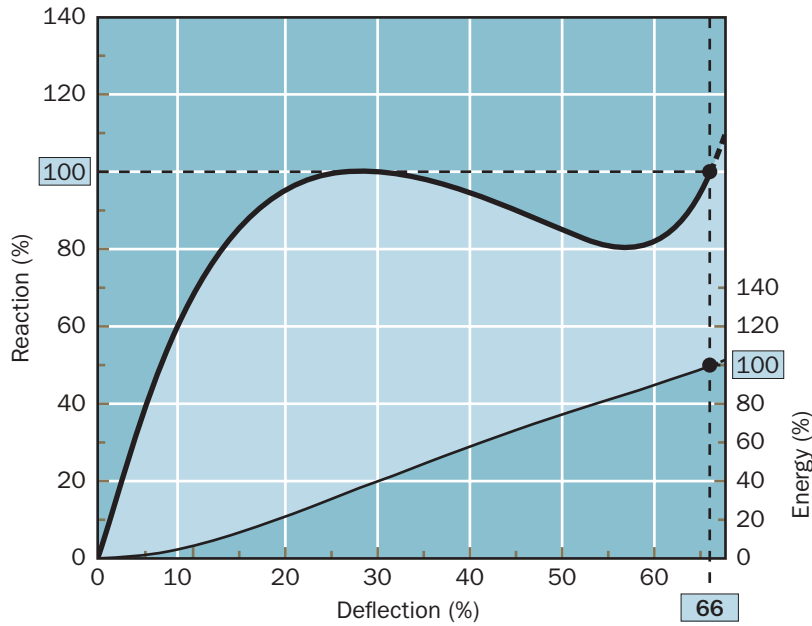

A		Compound A	Compound B
1000	E _R	989	604
	R _R	925	565
1050	E _R	1039	635
	R _R	971	593
1100	E _R	1088	665
	R _R	1017	621
1150	E _R	1138	695
	R _R	1063	650
1200	E _R	1187	725
	R _R	1110	678
1250	E _R	1237	756
	R _R	1156	706
1300	E _R	1286	786
	R _R	1202	734
1350	E _R	1336	816
	R _R	1248	763
1400	E _R	1385	846
	R _R	1295	791

All values are for a single element. [Units: kN, kNm]

Intermediate deflections

example

D _i (%)	0	5	10	15	20	25	30	35	40	45	50	55	60	66	67.5
E _i (%)	0	2	6	13	21	30	40	49	58	67	75	82	90	100	103
R _i (%)	0	35	63	83	95	99	100	98	94	90	85	81	81	100	110

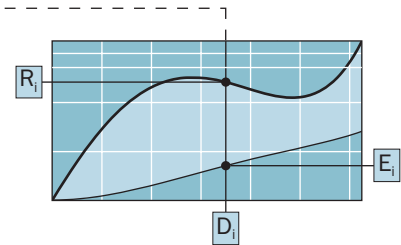

Nominal rated deflection may vary at RPD. Refer to p12-35.

All MI-2000S performance values are based on decreasing velocity (DV) method compression testing of full size elements on a dedicated high speed test press. Performances are valid for 150mm/s initial impact velocity, 23°C ambient temperature and 0° compression angle.

Site operating conditions or project specifications may differ from the above. Please ask your local Trelleborg Marine Systems office for further details, or visit our web site.



Trelleborg Marine Systems is part of Trelleborg's Engineered Systems Business Area and specialises in the safe berthing and mooring of vessels within ports and harbours, on offshore structures and in waterways around the world.

We bring together the industry's best known and respected brands for fendering and mooring systems with the unrivalled

collective experience and knowledge of its sales and engineering staff. Our customers benefit from great choice and helpful support at every stage from initial concept and detailed design right through to supply, commissioning and after-sales service – all provided by our network of regional offices and local agents.



Americas

Tel: +1 540 667 5191
tms.americas@trelleborg.com

Asia

Tel: +65 6268 8005
tms.asia@trelleborg.com

Australia

Tel: +61 2 9285 0200
tms.australia@trelleborg.com

Benelux

Tel: +31 180 434040
tms.benelux@trelleborg.com

Central Asia

Tel: +91 79 4003 8700
tms.india@trelleborg.com

France

Tel: +33 1 41 39 22 20
tms.france@trelleborg.com

Germany

Tel: +49 40 600 4650
tms.germany@trelleborg.com

Japan

Tel: +81 3 3512 1981
tms.japan@trelleborg.com

Middle East

Tel: +971 4 886 1825
tms.middleeast@trelleborg.com

Scandinavia

Tel: +46 410 51 667
tms.scandinavia@trelleborg.com

Spain

Tel: +34 945 437 906
tms.spain@trelleborg.com

UK

Tel: +44 1666 827660
tms.uk@trelleborg.com

Harbour Marine

Tel: +61 3 9575 9999
sales@harbourmarine.com

Presented by

Trelleborg AB has made every effort to ensure that the technical specifications and product descriptions in this catalogue are correct. The responsibility or liability for errors and omissions cannot be accepted for any reason whatsoever. Customers are advised to request a detailed specification and certified drawing prior to construction and manufacture. In the interests of improving the quality and performance of our products and systems, we reserve the right to make specification changes without prior notice. All dimensions, material properties and performance values quoted are subject to normal production and testing tolerances. This catalogue supersedes the information provided in all previous editions. If in doubt, please check with Trelleborg Marine Systems.

www.trelleborg.com/marine
tms@trelleborg.com

